

# **Olympic Tower Condominium**

## **ALTERATION AGREEMENT**

**AGREEMENT** made this \_\_\_\_\_ day of \_\_\_\_\_, 20 \_\_\_\_ between Olympic Tower Condominium (the "Condominium"), having an address at 641 Fifth Avenue, New York, New York (the "Building") and \_\_\_\_\_ ("Unit owner"), having an address at 641 Fifth Avenue, concerning work to be done to Unit # \_\_\_\_\_ (the "Unit") at the Building.

### **WITNESSETH:**

**WHEREAS**, the By-Laws of the require the prior written consent of the Condominium with respect to any addition, alteration or improvement in or to a Unit located in the Building; and

**WHEREAS**, the Unit owner has requested that the Condominium consent to the additions, alterations, and/or improvements to the Unit as shown in the architectural plans and specifications ("Plans"), prepared by \_\_\_\_\_ ("Architect") dated \_\_\_\_\_ as annexed hereto as Exhibit A and as shown in any additional correspondence between Condominium and/or its authorized representatives and Unit Owner and/or its authorized representatives (hereinafter collectively, the "Alterations") and hereto made a part of this Agreement, and

**WHEREAS**, the Condominium has designated its General Manager, John Lindstrom, as the "Alteration Administrator" to represent the Condominium concerning all matters pertaining to Alterations. The Condominium is managed by Douglas Elliman Property Management ("the Managing Agent").

**NOW, THEREFORE**, in consideration of the mutual agreements of the parties contained herein, the parties hereby agree as follows:

1. Consent. Provided Unit owner is in strict compliance with the terms of this Agreement the Condominium hereby grants its consent to the Unit owner to perform the Alterations to the Unit strictly in accordance with the Plans and upon those terms and conditions set forth herein. No amendments to the Plans or the scope of the Alterations shall be made without the prior written consent of the Condominium.
2. Prior to Work. Prior to commencing any work in connection with any of the Alterations to the Unit, the Unit owner agrees as follows:
  - (a) To deliver to Alteration Administrator a schedule of work to be performed by each contractor or subcontractor, and the time allotted to each trade, prepared by the Architect.
  - (b) To obtain the Condominium's written approval of all contractors and subcontractors to be hired by the Unit owner in connection with the Alterations [Each contractor must provide the indemnification letter attached as Exhibit 1 and a waiver of lien stating he will not place a lien on the Building];
  - (c) To deliver copies of all contracts with contractors and suppliers to the Alteration Administrator;
  - (d) To obtain, at the Unit owner's sole cost and expense, all necessary approvals and permits from any governmental authorities having jurisdiction with respect to the Alterations, including without limitation the Department of Buildings and, as applicable, the Landmarks Commission, and deliver within 10 days of receipt to the Alteration Administrator copies of all such approvals and permits, together with a copy of the Plans covering the Alterations which have been duly approved by the New York City Building Department.

- (e) To obtain from each contractor, subcontractor or other person working in connection with the Alterations to the Unit and deliver to the Alteration Administrator either policies or certificates evidencing that the following insurance coverage is in full force and effect in accordance with the Contractor's Insurance Requirements attached as Exhibit A.
  - (f) Unit owner will notify, in writing in the form of the letter attached as Exhibit B hereto (on Unit Owner's letterhead), the owners of units adjacent to, above and below the Unit which Alterations will be performed, their duration and that Unit owner will indemnify them for any damage whatsoever and another letter to the remaining residents of the floor (without indemnification), informing them of the upcoming work. Copies of each letter will be delivered to the Alteration Administrator before any work commences.
3. Fees. Unit owner shall pay all of the following fees, below and those outlined in Rider 1. Rider 1 dictates in the event of any conflicts in the fee amount.
- (a) Unit owner shall reimburse the Condominium and the Managing Agent for all fees, and expenses incurred by either, including architects, engineers and counsel, in connection with the review of the Plans and for subsequent or periodic inspections during or upon completion of the work, and any disputes in connection therewith.
  - (b) Unit owner shall pay **\$250.00 per day** as a Service fee to the Condominium for each calendar day the alteration period is extended beyond the Completion Date (see Section 5(a), below), for the use of the freight elevator, wear and tear on the building and general supervision, although this shall not diminish or be in lieu of any responsibility for any costs or damages hereunder.
  - (c) As partial security for its obligations under this Agreement, Unit owner hereby delivers to the Alteration Administrator, a cash deposit in the amount of 10% of the estimated cost of the Alterations, but not less than \$5,000.00 (the "Deposit") will be held by the Managing Agent to be applied, to cure the costs of the Condominium or any resident of the Building due to Unit owner's failure to comply with any term of this Agreement, including without limitation the costs of any outside consultant, damages caused by the work, or over time or security costs. Unit owner will supply any additional sums necessary so that the principal balance of the Deposit is never less than 10% of the cost of the Alteration. Any balance of the Deposit will be returned only at such time as the Condominium determines that the authorized work has been completed and all of Unit owner's obligations have been met.
  - (d) Alteration Processing Fee – See Rider 10. For reviewing, processing, and coordinating the plans of the architect/engineer, the work schedules of the various trades, insurance certificates from contractors and presenting the proposed Alterations to the Unit.
4. General Requirements. It is understood that:
- (a) Unit owner shall assume all risks of damage to the Building and its mechanical, heating, cooling, electrical or plumbing systems ("Systems") and to persons and property in the Building which may result from or be attributable to the Alterations being performed hereunder and all responsibility for the maintenance and repair of any Alterations and installations after completion. This responsibility covers all Alterations, whether or not structural, weather-tightness of windows, exterior walls or roofs, waterproofing of every part of the Building directly or indirectly affected by the work, and maintenance of all heating, plumbing, air-conditioning and other equipment installed or altered pursuant hereto. If the Condominium determines, in

its sole discretion, that the operation of the Building, or any of its equipment, or any Unit in the Building is adversely affected by the Alterations, Unit owner shall, when so advised, remove within 24 hours the cause of the problem and cease all work, or, at the Condominium's option, reimburse the Condominium on demand for all costs of removal and correction.

- (b) Unit owner recognizes that there will be no change in the operation of the Building's Systems to facilitate the functioning of any heating, air-conditioning, plumbing or electrical appliances Unit owner may be installing.
- (c) The alterations and materials used shall be of the quality and style in keeping with the general character of the Building.

The use of electric hammers, electric saws or other electrical power tools which cause or may cause undue disturbance to other residents of the Building are not permitted any time unless specifically approved by the Condominium in writing. No "jack-hammers" of any kind may be used.

- (d) Notwithstanding anything to the contrary contained herein, including the Condominium's consent to the Plans, the Unit owner acknowledges and agrees that the Alterations shall not adversely affect the structural integrity of the Building, any Units contained therein or any of the Building systems. The Unit owner recognizes that by granting consent to the making of the Alterations, the Condominium does not profess to express any opinion as to their design, feasibility or efficiency nor shall such consent be deemed to exonerate the Unit owner from any liability in connection with the Alterations.
- (e) Notwithstanding anything to the contrary contained herein, this Agreement shall in no way be construed as to give the Unit owner any right to either (i) perform any work or enter into an agreement for the performance of any work in, or obtain the right of access to any other Unit in the Building, or (ii) alter, modify, change, obstruct, or interfere with the use or maintenance of the Building, in connection with the performance of the Alterations contemplated hereby.

5. Work Period. Unit owner agrees the Alterations shall be completed expeditiously and in any event:

- (a) The work must commence within thirty (30) days of the mutual signing of this Agreement. The commencement of work shall be defined as the first day the work commences (the "Commencement Date"), as determined solely by the Alteration Administrator. If the work does not commence within 30 days of the mutual signing of this Agreement, this Agreement shall be null and void. All work shall be completed (all work has ceased in the Unit and all contractors have vacated the Unit, as determined by the Alteration Administrator) within \_\_\_\_\_ calendar days after the Commencement Date; which together will be defined as the "Completion Date." No work may be performed beyond the Completion Date without the prior written consent of the Condominium. If such consent is granted, Unit owner shall pay an administrative fee, to be determined by the Board of Managers for each day of work beyond the Completion Date, in addition to any fees set forth in Section 3(b) of this Agreement.
- (b) All demolition work shall commence on or after \_\_\_\_\_ and must be completed on or before \_\_\_\_\_. If the Condominium, in its sole discretion, permits demolition to occur beyond the aforesaid period, Unit owner shall pay an administrative fee, to be determined by the Board of Managers for each additional day, including weekends

and holidays.

- (c) Unit owner shall give the Alteration Administrator, notice at least three (3) working days prior to the date any demolition is scheduled to commence. The Unit owner understands that such demolition work or any work may be halted at any time if, in the Condominium's sole discretion, the Condominium shall determine that such work is excessively noisy or creates undue hardship for any other unit owner(s) or occupants. The Unit owner may recommence work at the sole discretion of the Alteration Administrator.
  - (d) No work shall be done, except as specified in scope defined as Alterations.
6. Dust. All precautions will be taken to prevent dirt and dust from permeating other parts of building during the progress of the Alterations. Materials and rubbish will be placed in barrels or bags, before being taken out of the Unit daily. All such barrels or bags, rubbish, rubble, discarded equipment, empty packing cartons and other materials will be taken out of the Building and removed from the Unit daily by the Unit owner's Contractor or, if it fails to do so, the Condominium at Unit owner's expense. Unit owner recognizes that only the service elevator may be used for such removal and only at such times as the Alteration Administrator, Chief Engineer, Assistant to the General Manager may direct. So that maximum security is provided, the Condominium at its sole discretion shall have the right to employ, at Unit owner's cost and expense, a uniformed security guard on whatever days and hours that may be required. Access to the Unit during Alteration may be limited to the service door. In no event may debris from the Alterations be allowed to remain in the hallways, basement or other public areas of the Building. Unit owner will insure that such public areas will be kept clean and will repair any damage caused by the removal of debris from the Unit. Unit Owner agrees to insure that applicable contractors are EPA Lead Safe certified renovators and that they follow EPA guidelines for lead safe renovations Rule 40 CFR Part 745 Lead Based Paint Renovation Repair and Painting Program for buildings built 1978 and before (effective 4/22/10).
7. House Rules. The Alteration shall not interfere with the normal daily operation of the building or violate the terms and conditions of the House Rules. Unit owner's contractors and/or subcontractors will follow and abide by the instructions of the Alteration Administrator or his designated representative. In the event it becomes necessary to operate on an "over-time basis," Unit owner agrees to reimburse the Condominium for any wages or related expenses incurred.
8. Indemnification and Release.
- (a) Unit owner shall indemnify and hold harmless the Condominium, Managing Agent, their Directors, officers, consultants and employees, and other Unit owners, tenants, visitors or occupants of the Building from all costs, liabilities or damages which arise as a result of the Alterations or any failure to comply with this Agreement, whether or not caused by negligence, and to reimburse the Condominium, Managing Agent, their consultants and employees and any Unit owner or occupant for any expenses (including, without limitation, attorneys' fees and disbursements) incurred as a result of such action.
  - (b) Unit owner hereby releases the Condominium, Managing Agent and their employees and consultants from any and all liability for loss or damage to any property which may result from or be in any way connected with the work, and Unit owner hereby waives any claims which it may now or hereafter have against the Condominium or Managing Agent based upon interruption or the suspension of the Alterations by the Condominium or Managing Agent regardless of the reason for such interruption or

suspension.

9. Liens. Unit owner will bear the entire cost of Alterations and installations and pay all bills incurred in connection therewith, not later than thirty days after completion of the work. If any mechanics liens are filed for work claimed to have been done or materials alleged to have been supplied, Unit owner shall cause such liens to be discharged within ten days after such filing. If Unit owner fails so to do, the Condominium may exercise any or all actions to discharge or satisfy such liens and charge Unit owner with all costs associated therewith, including attorneys fees.
10. Certificate of Occupancy. At the completion of the Alterations, Unit owner will do all things necessary at its expense and at the direction of the Condominium and Managing Agent to deliver an amended Certificate of Occupancy and a certificate of the Condominium of Fire Underwriters, if either be required, and such other proof as may be necessary to indicate all work has been done in accordance with all applicable laws, ordinances and Government regulations.
11. Smoke Detectors. Unit owner will have smoke detectors installed within 15 feet of every sleeping area on the ceiling or wall pursuant to Local Law 63 of 1981 of the City of New York, and Unit owner will install window guards if a child or children 10 years old or under lives or resides in the Unit pursuant to Section 131.15 of the New York City Health Code.
12. Failure to Pay. Any fees, costs, charges or penalties in connection with this Agreement which are not paid by the Unit owner within 10 days after bills therefore have been submitted to the Unit owner, shall be considered as Additional Common Charges, as provided for in the By-Laws of the Condominium shall be entitled to all its remedies provided for collection of Common Charges under the By-Laws of the Building and the laws of the State of New York.
13. Failure to Comply. Failure to comply with any of the provisions hereof shall be deemed a breach of the provisions of the By-Laws, pursuant to which approval has been granted, and, in addition to all other rights, the Managing Agent may also suspend all work and prevent workmen from entering the Unit for any purpose other than to remove their tools or equipment.
14. Assignment of Unit. Notwithstanding anything to the contrary contained in the By Laws, the Unit owner accepts sole responsibility for the work and costs in connection with the maintenance, repair, restoration, or replacement of any portions of the Unit affected by the work, and acknowledges that such responsibility shall pass to any successor-in-interest to the Unit owner in the Unit. If, after making any alterations or installing any equipment referred to herein, the Unit owner shall seek to transfer the common interest allocated to the Unit, as a condition prior thereto, the Unit owner shall provide the Condominium with an agreement, substantially in the form attached as Exhibit E, by that Unit owner's transferee is to assume all the Unit owner obligations hereunder, including the Unit owner's continuing obligations and understandings expressed herein.
15. Riders. All Riders Attached hereto are fully and incorporated herein and Unit owner agrees to be bound by them.
16. Miscellaneous. This Agreement may not be changed orally. This Agreement shall be binding on the Unit owner and the Condominium and their authorized successors and assigns.

**Unit owner**

By: \_\_\_\_\_

Name: \_\_\_\_\_

Title: \_\_\_\_\_

**Condominium**

By: \_\_\_\_\_

Name: \_\_\_\_\_

Title: \_\_\_\_\_

Receipt of Deposit in the amount of \$\_\_\_\_\_ acknowledged by Alteration Administrator.

Rider 1

Plumbing

In the event that new plumbing fixtures are to be installed, Unit owner agrees to replace all branch piping including hot and cold water shut-off valves between the new fixtures and the building risers. Unit owner will be responsible for all fees incurred in connection with the inspection of the condition of the Building's risers when exposed, the installation of the new plumbing fixtures, and the replacement of the branch piping, by the Building's architect and/or plumber. Unit owner will be responsible to notify the Chief Engineer when walls are open so that he may arrange for inspection of all risers by the building plumber at the building's expense.

As may be applicable, Unit owner hereby permits the Condominium to replace or make necessary repair to plumbing risers in the Unit during the Alteration. Such work shall be done at the Condominium's expense and shall be arranged so as not to conflict with the Schedule or unreasonably interfere with the Alterations.

Unit owner's initials: \_\_\_\_\_

Rider 2

Contractor License

A law concerning home improvement contracts went into effect in New York State on March 1, 1988. The provisions of this law apply to all home improvement contracts on or after March 1, 1988 for more than \$500.00 and addresses the issues of required licenses, contracts, and the manner in which a contractor conducts its business operations.

The Attorney General is responsible for enforcement of this law and information may be obtained by calling the Attorney General's office, (212) 341-2000 or (212) 341-2314 or writing to the:

New York Department of Law  
Bureau of Consumer Frauds and Protection  
120 Broadway – 3<sup>rd</sup> Floor  
New York, NY 10271

The New York City Department of Consumer Affairs web site allows visitors to verify contractor license information (<http://www.nyc.gov/html/dob/html/licenses/status.shtml>). Only licensed contractors will be permitted to work in the Building.

Unit owner's initials: \_\_\_\_\_



Rider 3

Asbestos

1. Unit owner shall comply with the requirements of Local Law No., 76 of 1985 by filing with the New York City Buildings Department appropriate asbestos evaluation forms by a certified asbestos investigator.
2. Copies of the asbestos investigator's New York City certification and the evaluation forms filed with the Buildings Department shall be delivered to the Alteration Administrator prior to the commencement of work.
3. In the event asbestos containing materials are disturbed by the work, Unit owner's Contractor shall, as required by law, employ only licensed and certified asbestos removal and disposal companies and handlers.
4. Evidence of licensing and certification of asbestos contractors shall be submitted to the Alteration Administrator prior to the commencement of work.

Unit owner's initials: \_\_\_\_\_

Rider 4

Restrooms

Contractors and subcontractors must use the bathroom in the Unit, or public restrooms located in the 645 public atrium, **not** the Building staff restroom.

Unit owner's initials: \_\_\_\_\_

Rider 5

Dust Removal

1. Individually seal all ventilation openings (supply and exhaust), doorways, windows, convectors, door grills, and other openings inside the work area with duct tape alone or with polyethylene sheeting at least six mils in thickness, taped securely in place with duct tape. Maintain seal until all work is completed. Take care in sealing of convector to avoid melting or burning of sheeting.
2. Cover carpeting in public hall with one layer of reinforced polyethylene sheeting at least 10 mils in thickness. Place corrugated cardboard or sheets of sound-deadening board on top of the polyethylene sheeting.
3. Sheet Plastic: Protect surfaces on the work area with one layer of plastic sheeting on floor and walls.
4. Cover floor of the work area with one layer of polyethylene sheeting, each at least six mils in thickness, turned up walls at least 12 inches.
5. Also see Rider 8.

Unit owner's initials: \_\_\_\_\_

Rider 6

Electrical Upgrades

1. No additional electrical service may be brought in without the Condominium's prior written approval. If such approval is granted, the Unit owner agrees to pay all professional fees and expenses associated with any review, correction, or amendment to the proposed electrical plans performed by the Condominium's engineer.
  
2. All requests to upgrade electrical service in Units will be handled in the following manner:
  - a) Increase in service to units may be limited at the discretion of the Board of Managers and/or based upon available service in the building.
  
  - b) The Condominium requires the placement of conduits or risers to major power sources be submitted as part of the initial submission and approved in advance. If there is not sufficient space in the stairwell, the riser can only be located outside the building - - in the rear with board approval. (Positioning of lines in basement to outside conduits or risers will be determined by the Alteration Administrator and the Chief Engineer. Note: If it is necessary to have a rigger's license to install new wires or conduit, the Unit owner will be so advised by the Alteration Administrator and the Unit owner will be liable for such charges.
  
  - c) Actual hook up to the Building's main service must be handled by an electrician selected by the Alteration Administrator, at Unit owner's expense.
  
  - d) The Unit owner agrees to perform all electric work in accordance with guidelines of the Condominium and the electrician it selects

Unit owner's initials: \_\_\_\_\_

Rider 7

Access to Pipes

The Unit owner will not, without the Condominium's prior written approval, enclose or obstruct access to the existing heat or water pipes, valves or gas lines or other equipment not presently enclosed. No plumbing or heating risers may be relocated without the Condominium's specific consent. In any event, whether or not approval is granted, the Condominium shall have the right to remove any impediments to access to such heat or water pipes, valves and equipment for that purpose and the Unit owner shall pay any expenses the Condominium may incur in removing these impediments, and shall assume all costs of restoring the same.

The Condominium may inspect all walls for concealed piping, valves, wiring and conduits before same are sealed.

Unit owner's initials: \_\_\_\_\_

Rider 8

Lead Based Paint Debris

The Unit owner shall cause the Unit owner's contractors and/or workers to use safe work practices during the work and take precautions to prevent the spread of dust and debris which may contain lead. The Federal Task Force in lead-Based Paint Hazard Reduction recommends:

1. Limiting access to the work area to only workers.
2. Covering the work area with six-mil polyethylene plastic or equivalent.
3. Protecting the workers.
4. Protecting the Unit owner's belongings by covering or removing them from the work area.
5. Wetting the painted surfaces before disturbing the paint.
6. Wetting the debris before sweeping.

The Task Force has indicated that certain removal practices are unsafe, including:

1. Open flame burning.
2. Power sanding or sandblasting (unless a special vacuum attachment is used to contain dust).
3. Dry scraping more than a *de minimis* surface area (*de minimis* means an area less than one square foot per room).

The Unit owner shall cause the Unit owner's contractors and/or workers to perform their work consistently with the recommendations of the Task Force.

The Unit owner shall cause the Unit owner's contractors and/or workers to perform specialized cleaning of the work area using methods designed to safely remove dust and debris which contain lead.

The Unit owner shall receive assurances acceptable to the Condominium from the Unit owner's contractors and/or workers that they have knowledge of lead based paint hazards and they will perform the work and clean up the work in a manner that will avoid creating lead-based paint hazards in accordance with applicable law.

The Unit owner's contractor shall comply with all applicable laws and regulations regarding work in pre-1978 buildings including, without limitation providing required notices and EPA pamphlets regarding lead hazards to the occupants in accordance with the Pre-Renovation Lead Information Rule of the EPA dated June 1, 1999. Rule 40 CFR Part 745 Lead Based Paint Renovation Repair and Painting Program for buildings built 1978 and before (effective 4/22/10).

Unit owner's initials: \_\_\_\_\_

Rider 9

Anti-Scald Valves

All new bathrooms or any renovated bathrooms must comply with Local Law 86 of 1996. The law calls for the installation of Anti-Scald Valves, on all tubs and showers, which would prevent the water temperature from exceeding 120 degrees. The law also requires that when tubs and showers are so equipped, the temperature of the hot water given off must be at least 110 degrees.

Unit owner's initials: \_\_\_\_\_

Rider 10

**DECORATIONS AND ALTERATIONS REVIEW PROCESS**

**THE START DATE OF ANY ALTERATION IS STRICTLY CONTINGENT UPON ITS POTENTIAL IMPACT ON THE QUALITY OF LIFE OF OTHER UNIT OWNERS AND BUILDING OPERATIONS. THEREFORE, THE START DATE OF A PROJECT MAY BE DELAYED/POSTPONED AT THE SOLE AND UNILATERAL DISCRETION OF THE BOARD OF MANAGERS.**

In order to ensure that your decoration or alteration review process proceeds expeditiously, we have prepared the following information to clearly explain the process. It is recommended that you familiarize yourself with all applicable policies, procedures and agreements, prior to executing any agreements with contractors and/or suppliers.

All work falls within one of two categories:

**Decorations** - Including, but is not limited to, painting, wall covering, refinishing of floors and other cosmetic work. Generally, will not require any approval by the engineer for the Building nor the Board of Managers, but work must comply with the Condominium's policies and procedures.

**Alterations** - Any type of construction. Will require approval by the engineer for the Building and the Board of Managers and work must comply with Building policies and procedures. Please review the attached *Alteration Policies and Procedures* prior to planning your alteration.

**STEPS OF THE REVIEW PROCESS**

**A. PROVIDE A WRITTEN EXPLANATION OF CONTEMPLATED WORK:**

**Decorations** - A letter outlining the work and estimated time of completion. Skip to and comply with Steps 6, below and remit a Decoration Processing fee, if applicable, payable to Olympic Tower Condominium.

**Alterations** – Submit scope of work and specifications, one electronic set of stamped architectural plans, **in PDF or CAD file format**, project flow chart/construction schedule (outlining each phase of construction) and contact information for Unit Owner's architect to the Alteration Administrator. Building's Architect will review and formulate comments, at Unit Owner's expense.

**B. OLYMPIC TOWER CHIEF ENGINEER WALKS THROUGH UNIT WITH INITIAL SET OF PLANS:**

Chief Engineer reviews plans, scope of work and walks through unit in order to formulate any comments or concerns that will be forwarded to Building's Architect.

**C. UNIT OWNER'S ARCHITECT ADDRESSES ALL BUILDING ARCHITECT'S ISSUES:**

- a. The amount of time necessary to complete this phase of the process is dependent upon the scope of work and completeness of the original submission. An Alteration



Administrator will administrate the review process. All plans and review comments will flow through the Alteration Administrator for distribution to the appropriate parties.

- b. The Unit Owner may begin the NYC Department of Building (NYC DOB) permit application process and the managing agent will execute applicable permit applications, with the expressed understanding that such accommodation does not imply any alteration approval (actual or conceptual) and that no work will commence until all Condominium approvals and conditions have been satisfied provided Unit Owner submits an acknowledgement on his/her letterhead stating:

*“This is to confirm that the signing of the forms by the building’s representative does not give us the permission to commence with the demolition or construction at the above referenced premises. The signing is for the purpose of expediting the building permit process. As discussed, we will await further permission from the NYC DOB and building management in order to commence with any demolition or construction as per approved plans.”*

D. PLANS SUBMITTED TO THE ALTERATION COMMITTEE FOR APPROVAL:

After the Unit Owner’s architect has completely addressed and satisfied all of the Building architect’s issues, the plans are submitted to the Alteration Review Committee for approval.

**Final plans must be submitted to Alteration Administrator blue print DOB approved fashion and in Adobe (PDF) or CAD electronic file format. A complete paper set must be maintained on the job site at all times.**

E. COMMENTS FROM THE ALTERATION COMMITTEE ARE ADDRESSED:

Depending on the nature of the comments, either the Building’s architect and/or the Unit Owner’s architect will address the comments until all comments have been resolved and approved by the Alteration Review Committee.

F. FINAL PREPARATIONS TO ALLOW SCHEDULING AND WORK TO COMMENCE:

The following items must be submitted:

- a. Fully executed Alteration or Decoration Agreement, as applicable, **and full compliance with all preconstruction agreement provisions.**
- b. Certificate of Insurance naming Olympic Tower Condominium and their respective employees, Oxford 1 Asset Management (USA) Inc., ARVIC Realty Corp, Olympic Tower LLC, Olympic Tower Associates Inc., Williston S.A., Victory Real Estate Development Corp., Wells Fargo Bank, N.A., Douglas Elliman Property Management and their respective employees and Olympic Gold LLC.
- c. Final project flow chart/construction schedule.
- d. All applicable NYC Department of Building permits for planned work.
- e. Copy of contract between Unit Owner and General Contractor.
- f. Copy of General Contractor Indemnification Letter listing its NYC license number.

- g. Proof that General Contractor is an EPA Certified Renovator.
- h. A letter from the Unit Owner's architect attesting to the accuracy of the estimated project value or a copy of the contractor's proposal/bid with the project value listed.
- i. Copy of Unit Owner's letters to adjacent Unit Owners and residents of the same floor.
- j. Remit Alteration Processing Fee – Payable to Olympic Tower Condominium
- k. Remit Alteration Deposit – Payable to Olympic Tower Condominium along with completed W-9.
- l. **Submit project plans in PDF format after each review, along with the final DOB submittal.**

### ALTERATIONS - PROCEDURES AND FEES

#### 1. TIME AT WHICH AN ALTERATION MAY COMMENCE:

No work can commence until: All permits and approvals are in place; All preconstruction Alteration Agreement provisions have been met; all parties have executed the Alteration Agreement; the Alteration Administrator has scheduled a start date and a "kick-off" meeting with the Chief Engineer has been completed. Subject to the scope of work, a typical Alteration should be completed within one-hundred twenty (120) days.

Factors such as the location and scope of work of your project, as it relates to other projects currently underway (in scope, location within the building, number of projects) and other common element building projects all are taken into consideration. The Condominium will not permit an alteration that places any one Unit Owner in a position of having more than one adjacent (side, above or below) alteration underway, at any one given time.

#### 2. DESIGN POLICIES AND PROHIBITIONS:

- a. No channeling of floor, wall, or ceiling slabs.
- b. No "wet areas" over "dry areas" (i.e. no bathrooms over libraries).
- c. Same room use over same room use (i.e. bedroom over bedroom).
- d. No noisy use over quiet use (i.e. no fitness rooms over bedrooms).
- e. The architect for the unit owner must assure the Condominium, in writing, that any floor installations shall meet or exceed the New York City Code from a sound transmission and impact noise rating standpoint.
- f. Cement board type product (not moisture resistant "Greenboard") must be used throughout all bathrooms indicating wall removal and replacement.
- g. Washing machine hook-up installations must include: (a) Stainless steel braided water supply hoses; (b) an automatic water shut-off valve in the event of hose failure; (c) Check valves to prevent hot & cold water crossover (d) A waterproof pan with a curb and drain under the unit(s).
- h. The installation of a whirlpool, Jacuzzi, any motorized bathtub, or similar devices is permitted strictly at the Unit Owner's risk and with the expressed understanding that if the Condominium, in its sole and unilateral discretion, deems that the installation creates a nuisance, or other adverse effect to another unit owner(s), the Unit Owner hereby agrees to cease using the device by removing the motor.
- i. Walls surrounding a steam shower installations must provide for a vapor barrier.

- j. Steam generators must be located within a waterproof pan with curb and drain.
- k. Installation of garbage disposals is prohibited.
- l. Common Element space cannot be incorporated into the alteration without written Board approval.
- m. No wooden floors are permitted in bathrooms.
- n. Installations of kitchen exhaust (hood) fans are NOT permitted. Re-circulating hoods ARE permitted.
- o. Installations of bathroom exhaust fans are NOT permitted. Re-circulating fans ARE permitted.
- p. Any existing kitchen or bath fan motors connected to Building systems/ductwork must be REMOVED.
- q. Only dryer exhaust is permitted to be ducted into Building dryer exhaust system.
- r. Whenever installing new shower body, contractor must install two (one hot + one cold) brass check valves.
- s. No space above the vertical fan coil units (in the vertical chase/shaft area that house the chilled & hot water supply and return HVAC water lines) can be reclaimed or breached for “built-ins” or other accessories.
- t. All motorized valves and thermostats for each vertical fan coil unit in the premises must be restored to working order and new isolation ball valves (Watts or similar) must be installed if existing valves are not functioning, at the time the motorized valves are replaced. It is highly *recommended* HVAC equipment installed when the building was first constructed or HVAC equipment that is thirty or more years old be replaced with the Building Standard specification. House Rule 35 (see Rider 11) stipulates when HVAC equipment *MUST* be replaced.
- u. Whenever motorized and/or shutoff valves for the chilled/hot water supply and return HVAC water lines are exposed, replaced or plans call for the installation of a built-in in such a way that would block access to said valves, an access panel must be installed and the built-in must be designed for easy removal in the event access to the valves are required.
- v. Contractor must remove existing paper over fiberglass insulation on any chilled water supply and return HVAC water line whenever such lines are accessible and/or exposed, with Armorflex type rubber/waterproof insulation.
- w. Contractor must install moisture resistant “Greenboard,” (double layer, if necessary, to match existing thickness) whenever replacing wallboard surrounding the chilled/hot supply & return HVAC water lines.
- x. Unit owners who expose original and/or damaged drain traps, located in their unit, but servicing the unit above, must replace the traps at their expense, without charging the unit owner above.
- y. Bathroom basins must have design features to prevent overflows.

**Other Recommendations, which are not required:**

- z. For renovations involving demolition from the entry door of the unit, to the unit’s telecommunications closet, contractor should install new communications junction box on unit side of corridor wall (as close to ceiling as possible) and run new communication cable (that will accommodate phone/cable/internet service, etc.) from junction box to unit’s telecommunications closet, in the event unit owner may submit a request to run new such cable in the corridor ceiling area in order to receive any of the applicable/additional services to the unit.

3. DEMOLITION:

To the extent feasible, all demolition must be scheduled at the “front end” of the project.

4. DURATION OF THE ALTERATION:

The duration of the alteration, as submitted by the Unit Owner's architect, must be considered attainable and realistic by the Building's architect, Alteration Administrator, Chief Engineer and Board of Managers. If an extension is granted to go beyond the stated term in the Alteration Agreement, such extension is subject to a daily fee, to be determined by the Board of Managers.

5. WORK DAYS / WORK HOURS / HOURS OF NOISY WORK / HOLIDAYS / SHUT-DOWNS:

- a. Work Days: Weekdays, except below listed exceptions and holidays. No work on weekends.
- b. Work hours: 9:00AM to 4:30PM all Contractors must be out of the Building NO LATER THAN 5:00PM.
- c. Hours of noisy work: 11:00AM to 12:30PM and 1:30PM to 3:30PM (or at other intervals/ lengths of time subject to the sole and unilateral discretion of the General Manager, Assistant to the General Manager and/or Chief Engineer).
- d. No work Wednesday, Thursday or Friday during Thanksgiving week.
- e. No work 12/24 through 1/1.
- f. No working on Federal holidays, including, but not limited to: New Years, Martin Luther King, Presidents Day, Good Friday, Memorial Day, Fourth of July, Labor Day, Rosh Hashanah, Yom Kippur, Columbus Day.
- g. Water shut-downs must be scheduled with the Chief Engineer and can only occur between the hours of 10:00AM and 2:00PM (at intervals/a length of time subject to the sole and unilateral discretion of the General Manager, Assistant to the General Manager, and /or Chief Engineer)

6. WRITTEN NOTICE OF ALTERATION/DECORATION TO ADJACENT UNIT OWNERS:

Unit Owner will send each adjacent Unit Owner a letter describing the general extent of the alteration and its duration; at least one week prior to the commencement of work. The letter must also include indemnification language to ensure that the Unit Owner performing the alteration will remedy all damages that result from the alteration. See sample contained within the Alteration Agreement.

7. TOOL PROHIBITIONS:

No impact tools may be used at any time.

8. INSPECTION BY BUILDING'S ARCHITECT:

During demolition, the construction phase and immediately before closing walls/ceilings/floors containing building service lines, the Condominium reserves the right, at its sole and unilateral discretion, to have the architect/engineer for the Condominium perform inspection(s) at the Unit Owner's expense.

9. FEES AND SECURITY DEPOSITS:

- a. ***Alteration Processing Fee:*** Unit Owner will remit an alteration processing fee of \$500 payable to Olympic Tower Condominium. Effective 1/15/15, not applicable to projects with scope of work limited to HVAC replacement only.
- b. ***Decoration Processing Fee:*** Unit Owner will remit a decoration processing fee of \$-0- payable to Olympic Tower Condominium

- c. **Water Shutdown Fee:** ~~Each alteration will include TWO water shutdowns per alteration at no cost. The third and fourth water shutdowns will cost \$500 and \$1,000 respectively, with water shutdowns thereafter costing \$2,000 each. These fees are waived for voluntary (not mandated) HVAC replacement projects. These fees have been suspended effective 1/15/15.~~
- d. **Administrative Fee For Incomplete Projects:** If an extension is granted to go beyond the stated term in the Alteration Agreement, such extension is subject to a daily fee, to be determined by the Board of Managers.
- e. **Elevator Service Fee:** Unit owner shall pay \$250.00 per day as a Service fee to the Condominium for each day the alteration period (that workers or supplies are moved into or out of the building) is extended beyond its Completion Date, for the use of the freight elevator, wear and tear on the building and general supervision, although this shall not diminish or be in lieu of any responsibility for any costs or damages hereunder.
- f. **Security Deposit:** Unit Owner must remit a Security Deposit in an amount of ten percent (10%) of the project value (including contractor and sub-contractor costs) or \$5,000 whichever is greater, and complete an IRS Form W-9 (see attached) for purposes of establishing a security deposit account at a financial institution.

At the conclusion of the alteration and **prior to the return** of the security deposit, Owner must submit the following items to the Alteration Administrator: 1. For all projects that were filed with the NYC DOB, a Letter of Completion issued by the NYC DOB (and a Certificate of Completed Electrical Work by the contractor, as applicable); 2. A letter from the Owner stating the actual work completed conforms, in its entirety, to the plans and specifications approved by the Board of Managers; 3. A letter from the architect (or the contractor) stating the actual work completed meets or exceeds all applicable NYC building codes. 4. HVAC Hydronic Test Report if the HVAC systems were replaced. 5. No other open issues pertaining directly or indirectly to the Alteration.

#### 10. WORK STOPPAGE:

Any of the following persons will retain the right to stop work and/or waive “administrative fees” for a breach of any of the terms of the Alteration Agreement and/or these Policies and Procedures: Any member of the Board of Managers; Any member of the Alteration Review Committee; The General Manager; Assistant to the General Manager; The Chief Engineer and or any member of Management.

#### 11. OTHER PROVISIONS:

- a. Contractors and/or their suppliers agree not to block the main entrance to the building.
- b. Contractors must use low odor products whenever possible and use window ventilation whenever weather permits.
- c. Contractor must seal all air exhaust registers and the entry door to the unit, prior to any painting, sanding, demolition and/or dust producing work.
- d. Contractor must inspect unit entry door, setback, door frame and compactor room doors and walls for scratches, marks and “touch-up” said marks DAILY. If the repainted areas are visible after the “touch-up,” contractor must repaint the entire section to ensure a blemish free appearance.
- e. If the existing one piece tank/bowl toilets will remain as part of the alteration, the contractor must adjust the height of the toilet tank overflow tube so it will not permit water to rise to a level that can cause water to leak from the toilet’s bolt holes (used for mounting the toilet seat) and adjust the water level so that the water level will not rise to the level of the bolt holes.

#### 12. HVAC CHANGES:

- f. The OTC Specifications for these units must be adhered to. No other changes will be considered. Once installed, a final Hydronic Test Report must be performed. This report must be submitted as part of the final sign off of the project before the security deposit returned.

**NON-COMPLIANCE WITH THE ABOVE AND/OR DEVIATION FROM THE PLANS  
APPROVED BY THE CONDOMINIUM WILL RESULT IN AN IMMEDIATE JOB SHUTDOWN  
OF ALL WORK.**

## Rider 11

Olympic Tower Condominium

House Rule 35

Adopted February 24, 2009

Amended 1/11/13

Unit owners are required to replace all HVAC equipment, including associated unit and piping insulation and valves, within their apartment Units as noted below. This rule applies to existing equipment that is original to the building or is older than 30 years.

1. Within one year of the transfer of any form of legal ownership of a Unit,
2. Within six months of the vacancy of the tenant or occupant of the Unit and Prior To Any Re-Occupancy:
  - a. Upon the vacancy of a lessee occupying an apartment.
  - b. Upon the vacancy of the owner occupant and their family occupying an apartment in order to lease the apartment or To Authorize Another Individual To Take Occupancy.
  - c. Upon the change in the authorized occupant and their family occupying an apartment by an entity owner.
3. In conjunction with an apartment alteration as required in the Alteration Agreement or whenever the interior Alteration will entail opening the walls surrounding an HVAC Unit.
4. When any HVAC equipment found to be defective, damaged or deteriorated, the equipment must be immediately repaired or replaced by the Unit Owner.

If the Unit Owner fails to comply with the required replacement and schedule as specified above, the unit owner will be assessed an Administrative Fee of Five Hundred and no/100 dollars (\$500.00) per month until such replacement(s) is/are complete and, the following services **will not be tendered** to all residents of the Unit, whether or Owner or tenant Until the HVAC equipment is replaced:

1. Housekeeping and/or maintenance requests that are a Unit Owner's responsibility (which could have been performed by the staff and billed back to the Unit Owner as an additional charge) will not be provided.
2. Fax and Xeroxing services will not be provided.
3. Concierge services will not be provided:
  - a) No visitors, guests, delivery or service people will be allowed beyond the desk unless personally escorted by the resident, nor will the concierge call the apartment to advise them of their arrival.
  - b) Visitors will have to call from outside the building to announce their arrival.
  - c) No authorization to enter or to release keys will be honored.
  - d) No packages or deliveries of any kind (except prescription medication) will be accepted by the concierge.
  - (e) The concierge will not order limousines, make restaurant reservations or arrange tickets for the theater or any other form of entertainment.
  - (f) No service calls will be provided to the apartment except

Unit owner's initials: \_\_\_\_\_

Exhibit A

**Olympic Tower Contractors Indemnification/Insurance Agreement**  
**(Please complete all applicable sections colored red)**

The execution of Exhibit “A” represents an agreement between Olympic Tower Condominium (“OTC”) and \_\_\_\_\_ (**Contractor/Mover**) requiring that the contractor agrees to indemnify and hold the Additional Insured harmless in accordance with the below provision and to provide all of the insurance coverages required as attached. Specifically, during the time work is being completed, the contractor will include the below listed Additional Insured and any unit owner or specific representative requested as an Additional Insured under their General Liability/Umbrella policies during the time work is being performed.

Hold Harmless/Indemnification Provision

Contractor, its sub-contractors, and/or Moving Company shall, to the fullest extent permitted by law at its own cost and expense, defend, indemnify and hold the Insured, its directors, officers, employees, agents and representatives harmless from and against any and all claims, loss (including attorney fees, witness fees and all court course costs) damages, expenses and liability resulting from injury and or death of any person, or damage to or loss of an property arising out of any negligent or wrongful act, error, omission or breach in connection with the operations of Contractor, sub-contractor, and/or Moving Company, its employees, agents and representatives. The foregoing indemnity shall include injury or death of any employee, associate, independent contractor of the Company and shall not be limited in any way by the amount or type of damages, compensation or benefits payable under any applicable workers’ compensation, disability benefits or other similar employee similar benefits acts. This provision shall survive the termination or expiration of this agreement.

---

**Name of Authorized Representative of Company**

AGREED: \_\_\_\_\_ AGREED: *John Lindstrom*, Gen Mgr/Asst Sec.  
**Signature of Authorized Representative of Company** Authorized Representative for OTC

---

**As applicable, Contractor's NYC Department of Consumer Affairs License Number**

**Additional Insured:**

Olympic Tower Condominium and their respective employees, Oxford 1 Asset Management (USA) Inc., ARVIC Realty Corp, Olympic Tower LLC, Olympic Tower Associates Inc., Williston S.A., Victory Real Estate Development Corp., Wells Fargo Bank, N.A., Douglas Elliman Property Management and their respective employees and Olympic Gold LLC.

---

**Unit Owner's Name and Unit Number**

---

**Date**



## **Insurance Coverage Amounts As Required in Exhibit “A”**

Contractor and its Subcontractors shall not commence work until it has obtained all required coverages and limits referred to herein and provide evidence of coverage set forth, which has been reviewed and approved by Olympic Tower Condominium (“OTC”).

Contractors and its Subcontractors shall obtain and maintain at its own cost and expense throughout the term of this agreement the following coverages and limits:

1. **PROPERTY INSURANCE** upon all tools, material and equipment (owned, borrowed or leased by the contractor or their employees) to the full replacement value thereof during the full term of this contract. The insurance shall insure against damage or loss caused by fire and all other perils covered by a standard Special Causes of Loss ("All Risk") insurance policy. Contractors agree to waive any and all rights of subrogation against OTC for loss or damage to any property required to be covered under this provision.
2. **WORKERS COMPENSATION AND EMPLOYERS LIABILITY** insurance affording coverage under the Workers Compensation laws of the State of New York and Employers Liability coverage subject to a limit of no less than Five Hundred Thousand Dollars (\$500,000) each employee, Five Hundred Thousand Dollars (\$500,000) each accident, Five Hundred Thousand Dollars (\$500,000) policy limit. The policy shall be endorsed to include a “waiver of subrogation” endorsement in favor of OTC.
3. **COMMERCIAL GENERAL LIABILITY (2007 FORM OR EQUIVALENT)** - This policy shall provide a One Million Dollar (\$1,000,000) combined single limit for Bodily Injury and Property Damage with a Two Million Dollar (\$2,000,000) general aggregate limit (per project) and be written on an “occurrence form”. The policy shall provide Products/Completed Operations coverage with a Two Million Dollar (\$2,000,000) limit and Personal Injury Liability with a One Million Dollar (\$1,000,000) limit. The policy will include coverage for Independent Contractors performing services on behalf of the contractor, Broad Form Property Damage and Contractual Liability (specifically covering the indemnity found under this agreement). The policy shall be endorsed to include OTC as an ***Additional Insured***. Definition of Additional Insured shall include all Officers, Employees and Agents representing OTC – See Certificate of Insurance sample for other entities that must also be listed as *Additional Insured*.

The coverages for an *Additional Insured* shall apply on a Primary and Non-Contributory basis irrespective of any other insurance, whether collectible or not and specifically include “Completed Operations” coverage for each Additional Insured. The policy shall contain a waiver of subrogation endorsement in favor of OTC. The policy cannot include any exclusion relating to an “injury to an insured employee (action over)” that negates the contractual liability exception under this policy.

4. **AUTOMOBILE LIABILITY (if applicable)** - The policy shall provide Liability insurance under Symbol “1”, providing a One Million Dollar (\$1,000,000) combined single limit for Bodily Injury and Property Damage and covering all owned, non-owned and hired vehicles of the contractors/subcontractors.
5. **UMBRELLA LIABILITY** - An Umbrella policy must be purchased with a limit of not less than \*Five Million Dollars (\$5,000,000), providing excess coverage over all limits and coverages noted in Paragraphs 2, 3 and 4 above without exception. These limits can be obtained by a combination of Primary and Excess Umbrella policies, provided that all layers follow form with the underlying policies. The policies shall be endorsed to include OTC as an *Additional Insured* as defined under Paragraph 3 above.

All policies discussed above shall be written with insurance companies licensed and admitted to do business in the State of New York and rated no lower than A VIII in the most current edition of A.M. Best's Rating Guide, and "BBB" in Standard & Poor's. All policies discussed above shall be endorsed to provide that in the event of a cancellation, non-renewal or material modification, OTC shall receive thirty (30) days prior written notice by certified mail, return receipt requested. The coverage required under paragraph 3 (Commercial General Liability) cannot be subject to a deductible or self-insured retention without owners prior approval.

6. **COMPLIANCE DOCUMENTATION** – The Contractor shall furnish OTC with Certificates of Insurance evidencing compliance with all insurance provisions noted above no later than seven (7) days prior to commencement of work. The contractor is also required to furnish a copy of the actual endorsements including OTC as an Additional Insured(s) under this agreement and any non-standard exclusion endorsement attached to the Commercial General Liability Policy. All certificates, endorsements and policy termination notices shall be delivered to:

**ASSISTANT TO THE GENERAL MANAGER  
OLYMPIC TOWER CONDOMINIUM  
641 5<sup>TH</sup> AVENUE, C1  
NEW YORK, NEW YORK 10022**

\* Umbrella limit subject to negotiation based on scope & type of work.

**FAILURE TO COMPLY WITH ANY OF THE INSURANCE PROVISIONS NOTED ABOVE WILL RESULT IN A BREACH OF THIS AGREEMENT BY THE CONTRACTOR/SUBCONTRACTOR AND CONTRACTOR/SUB-CONTRACTORS WILL NOT BE ALLOWED TO START WORK.**

Exhibit B

**SAMPLE LETTER #1 of 2 NEEDED - NOT FOR DISTRIBUTION**

**PUT ON UNIT OWNER'S LETTERHEAD**

**AT LEAST ONE WEEK PRIOR TO THE COMMENCEMENT OF ANY WORK GIVE THE MANAGEMENT OFFICE A COPY OF THIS LETTER SO...**

**IT CAN BE DISTRIBUTED TO:** UNIT OWNERS SHARING A COMMON WALL (ON EITHER SIDE) AND TO THE UNITS IMMEDIATELY, ABOVE AND BELOW THE UNIT UNDER ALTERATION.

Date: \_\_\_\_\_

641 Fifth Avenue, Unit# \_\_\_\_\_  
New York, NY 10022

Dear Neighbor:

In accordance with the Alteration Agreement between me and the Olympic Tower Condominium ("the Condominium"), covering the alterations to be performed in my Unit \_\_\_\_\_, please be advised of the following:

- The alterations will be commencing on or about \_\_\_\_\_ ("Anticipated Commencement Date"). The Alteration Agreement with the Condominium permits me \_\_\_\_\_ calendar days to complete the alteration.
- The scope of work will generally include:

\_\_\_\_\_  
\_\_\_\_\_

- I hereby agree to indemnify you for any damage whatsoever to your unit caused by the alterations performed in my Unit. I agree to pay the reasonable cost of repair of such damage. At your option, such repair may be performed, at my expense, by contractors of your choice or by my contractors.
- In order to take advantage of the foregoing indemnification, you must permit my designated representative, in the presence of the Condominium's Chief Engineer, to inspect your unit prior to the Anticipated Commencement Date of my alterations. Please call my designated

Representative \_\_\_\_\_, at \_\_\_\_\_ to arrange the inspection. You must also permit my designated representative to inspect any damage you claim my alterations have caused.

Please contact me if you have any other questions or if I can be of further assistance.

\_\_\_\_\_  
Unit Owner

Phone: \_\_\_\_\_

Date: \_\_\_\_\_

**SAMPLE LETTER #2 of 2 NEEDED - NOT FOR DISTRIBUTION**

**PUT ON UNIT OWNER'S LETTERHEAD**

**AT LEAST ONE WEEK PRIOR TO THE COMMENCEMENT OF ANY WORK GIVE THE MANAGEMENT OFFICE A COPY OF THIS LETTER SO...**

**IT CAN BE DISTRIBUTED TO:** THE REMAINING UNIT OWNERS ON SAME FLOOR AS THE UNIT UNDER ALTERATION.

Date: \_\_\_\_\_

641 Fifth Avenue, Unit# \_\_\_\_\_  
New York, NY 10022

Dear Neighbor:

In accordance with the Alteration Agreement between me and Olympic Tower Condominium ("the Condominium"), covering the alterations to be performed in my Unit \_\_\_\_\_, please be advised of the following:

- The alterations will commence on or about \_\_\_\_\_. The Alteration Agreement with the Condominium permits me \_\_\_\_\_ calendar days to complete the alteration.
- The scope of work will generally include: \_\_\_\_\_  
\_\_\_\_\_  
\_\_\_\_\_  
\_\_\_\_\_  
\_\_\_\_\_

Please contact me if you have any other questions or if I can be of further assistance.

\_\_\_\_\_  
Unit Owner

Phone: \_\_\_\_\_

Date: \_\_\_\_\_

Exhibit C

**PROTECTION DETAIL  
REQUIRED FOR ALL ALTERATIONS/DECORATIONS & MOVES  
EFFECTIVE 07/06/2010**

The below indicated protection detail MUST be in place BEFORE any work or move will be allowed to take place.

**Daily Protection Detail**

Trash Room: No special protection required, unless demolition (see below).

Corridor

1. From Trash Room to Unit - Cover carpeting with Masonite over paper (such as Sisal Paper, which is a polystrand reinforced paper). Do not use a colored paper that can bleed if it gets wet.
2. For "A," "H," "D," "E" Units - Place Masonite over paper on marble apron at end of corridor.

Elevator Landing Area Carpeting

Cover solid green carpeting with polyethylene carpet protection tape with self adhesive back of at least 2.5 mil in thickness; such as 3M Protective Carpet Tape 2E93-EZ.

Note: Bulky items being moved MUST be in boxes or wrapped in blankets unless walls are covered with Masonite.

**Demolition Debris Protection Detail**

In ADDITION to Daily Protection Detail above:

1. Cover Trash Room Floor with Masonite.
2. Cover Trash Room Marble Saddle with Masonite (if no door clearance, use paper).
3. Cover Bottom 4' of Trash Room Door with Masonite.
4. Cover Corridor walls from Trash Room to Unit with Masonite on scheduled day(s) of demolition.
5. Cover all doorjambes and intersection corners with cardboard or plastic guards of approximately 1/4" thick.

**Other Information**

Building prefers that contractors use GREEN No-Stick Floor Protection tape, instead of BLUE painter's tape, when taping to walls or floors.

**Please contact Management (212.486.9400 x1) with any questions.**

---

CONTRACTOR ACKNOWLEDGE AND AGREE TO FOLLOW:

---

**Contractor Name**

**Signature**

**Date**

## Exhibit D

### BUILDING STANDARD LOCKSETS

(As of June 2008, the building lockset standard is as follows) – Revised 10-27-10

Olympic Tower Condominium  
641 Fifth Avenue  
New York, New York 10022  
212.486.9400

#### Bottom Entry Lock

Schlage Commercial/Heavy Duty Grade  
L9453

“L” trim plate (which is 1 3/4” wide)

#42 (D Orbit) Ball type knob

Outside: Oil Rubbed Bronze #613 finish

Inside: TBD by Unit Owner. Polished Chrome #625 was original to the apartment.

(Lead time from the manufacturer on the above may be 4-6 weeks)

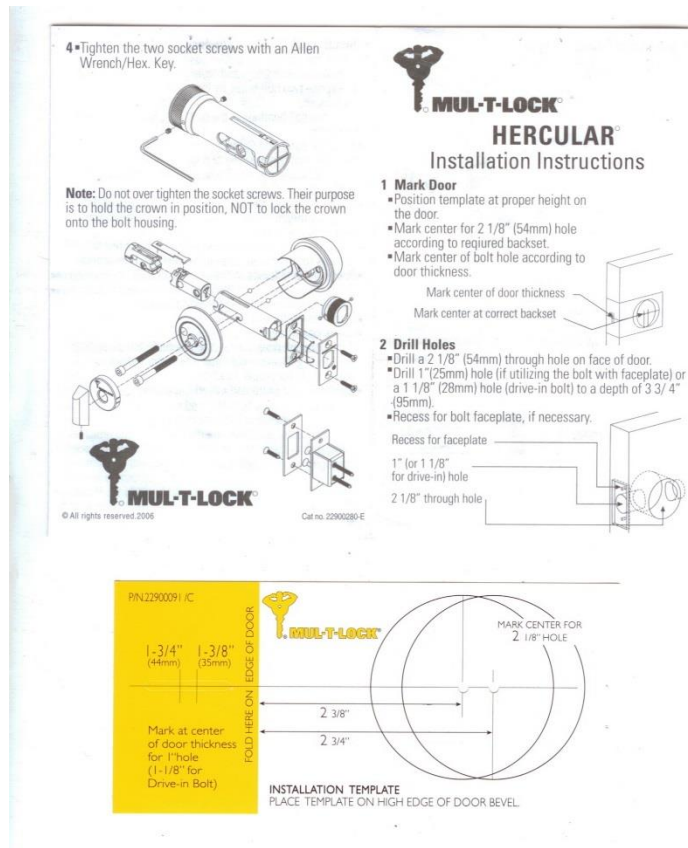

**Exhibit D – Continued**

**Upper Deadbolt – If Using Deadbolt**

MUL-T-LOCK Hercular (tubular) dead bolt  
2.75" back set  
Oil Rubbed Bronze #613 finish (US10B)

Note: Locksets below **NOT** shown in Building Standard Finish. Below finish is **NOT** allowed.



Exhibit E

**AGREEMENT PERTAINING TO  
IMPROVEMENTS AND /OR BETTERMENTS  
IN OR TO THE UNIT**

**WHEREAS**, by certain Deed for Unit # \_\_\_\_\_ (the "Unit"),

\_\_\_\_\_ ("Owner") acquired all of the right, title and interest of Seller or his/her predecessor in Interest, in the Unit, which dimensions are defined in Section 6 of the Declaration of the condominium known as Olympic Tower Condominium, 641 Fifth Avenue, New York, New York (the "Condominium"); and

**WHEREAS**, by virtue of the Deed, Owner will be subject to all of the obligations of Seller under the By Laws of the Condominium (the "By-Laws").

**NOW, THEREFORE**, in consideration of executing the Alteration Agreement by the Condominium or its authorized agent, Owner hereby acknowledges and/or reiterates (as may be the case) that Owner took the Unit, in its entirety and hereby assumes all responsibility for all improvements and/or betterments in or to or the Unit, irrespective of when such improvements and betterments may have been made to the Unit.

Furthermore, such responsibility includes, without limitation, the obligation to maintain and repair, such improvements, betterments in or to the Unit and any structures, fixtures, appliances, or other items installed or built in connection with all alteration work and to immediately correct any deficiencies regarding the same, at the Owner's expense, as directed by the Condominium or its authorized agent.

In the event Owner does not immediately correct deficiencies, Condominium reserves the right to correct the deficiencies and bill the cost of to correct the deficiencies to the Owner as Additional Common Charges.

Any breach of this Agreement or the obligations assumed hereby shall be a breach of the By Laws.

This Agreement and all of its provisions shall be binding on Owner and his/her estate, heirs, executors, administrators, personal representatives, successors and assigns.

\_\_\_\_\_  
OWNER Date

\_\_\_\_\_  
OWNER Date



**Certificate of Foreign Status of Beneficial Owner for United States Tax Withholding and Reporting (Individuals)**

(Rev. February 2014)

► For use by individuals. Entities must use Form W-8BEN-E.

OMB No. 1545-1621

Department of the Treasury  
Internal Revenue Service

► Information about Form W-8BEN and its separate instructions is at [www.irs.gov/formw8ben](http://www.irs.gov/formw8ben).

► Give this form to the withholding agent or payer. Do not send to the IRS.

**Do NOT use this form if:**

**Instead, use Form:**

- You are NOT an individual . . . . . W-8BEN-E
- You are a U.S. citizen or other U.S. person, including a resident alien individual . . . . . W-9
- You are a beneficial owner claiming that income is effectively connected with the conduct of trade or business within the U.S. (other than personal services) . . . . . W-8ECI
- You are a beneficial owner who is receiving compensation for personal services performed in the United States . . . . . 8233 or W-4
- A person acting as an intermediary . . . . . W-8IMY

**Part I Identification of Beneficial Owner (see instructions)**

1 Name of individual who is the beneficial owner		2 Country of citizenship	
3 Permanent residence address (street, apt. or suite no., or rural route). <b>Do not use a P.O. box or in-care-of address.</b>			
City or town, state or province. Include postal code where appropriate.		Country	
4 Mailing address (if different from above)			
City or town, state or province. Include postal code where appropriate.		Country	
5 U.S. taxpayer identification number (SSN or ITIN), if required (see instructions)		6 Foreign tax identifying number (see instructions)	
7 Reference number(s) (see instructions)		8 Date of birth (MM-DD-YYYY) (see instructions)	

**Part II Claim of Tax Treaty Benefits (for chapter 3 purposes only) (see instructions)**

9 I certify that the beneficial owner is a resident of \_\_\_\_\_ within the meaning of the income tax treaty between the United States and that country.

10 **Special rates and conditions** (if applicable—see instructions): The beneficial owner is claiming the provisions of Article \_\_\_\_\_ of the treaty identified on line 9 above to claim a \_\_\_\_\_ % rate of withholding on (specify type of income): \_\_\_\_\_

Explain the reasons the beneficial owner meets the terms of the treaty article: \_\_\_\_\_

**Part III Certification**

Under penalties of perjury, I declare that I have examined the information on this form and to the best of my knowledge and belief it is true, correct, and complete. I further certify under penalties of perjury that:

- I am the individual that is the beneficial owner (or am authorized to sign for the individual that is the beneficial owner) of all the income to which this form relates or am using this form to document myself as an individual that is an owner or account holder of a foreign financial institution,
- The person named on line 1 of this form is not a U.S. person,
- The income to which this form relates is:
  - (a) not effectively connected with the conduct of a trade or business in the United States,
  - (b) effectively connected but is not subject to tax under an applicable income tax treaty, or
  - (c) the partner's share of a partnership's effectively connected income,
- The person named on line 1 of this form is a resident of the treaty country listed on line 9 of the form (if any) within the meaning of the income tax treaty between the United States and that country, and
- For broker transactions or barter exchanges, the beneficial owner is an exempt foreign person as defined in the instructions.

Furthermore, I authorize this form to be provided to any withholding agent that has control, receipt, or custody of the income of which I am the beneficial owner or any withholding agent that can disburse or make payments of the income of which I am the beneficial owner. **I agree that I will submit a new form within 30 days if any certification made on this form becomes incorrect.**

**Sign Here**



-----  
Signature of beneficial owner (or individual authorized to sign for beneficial owner)

-----  
Date (MM-DD-YYYY)

-----  
Print name of signer

-----  
Capacity in which acting (if form is not signed by beneficial owner)

Supplemental Information  
For IRS Forms W-8BEN or W-8BEN-E

**NOTE:** Use this form if a United States mailing address and/or a US phone number is listed on any IRS Form W-8BEN or W-8BEN-E submitted by a depositor.

**TO THE DEPOSITOR:**

The listed mailing address and/or phone number you submitted as an Apple Bank depositor on IRS Form W-8BEN or W-8BEN-E is located within the United States of America (USA).

1. State below the reason(s) why a USA mailing address was used:

---

---

---

2. State below the reason(s) why a USA phone number was used:

---

---

---

3. Provide documentary identification evidence establishing your foreign status, as set forth in your Form W-8BEN or W-8BEN-E:

Specify Document Type:

---

Date: \_\_\_\_\_

X \_\_\_\_\_

Depositor Signature

\_\_\_\_\_  
Name (*print above*)

*For Bank Use Only:*

Branch: \_\_\_\_\_

Signature: \_\_\_\_\_

Date: \_\_\_\_\_

# Certificate of Status of Beneficial Owner for United States Tax Withholding and Reporting (Entities)

(February 2014)  
Department of the Treasury  
Internal Revenue Service

▶ For use by entities. Individuals must use Form W-8BEN. ▶ Section references are to the Internal Revenue Code.  
▶ Information about Form W-8BEN-E and its separate instructions is at [www.irs.gov/formw8bene](http://www.irs.gov/formw8bene).  
▶ Give this form to the withholding agent or payer. Do not send to the IRS.

**Do NOT use this form for:**

**Instead use Form:**

- U.S. entity or U.S. citizen or resident . . . . . W-9
- A foreign individual . . . . . W-8BEN (Individual)
- A foreign individual or entity claiming that income is effectively connected with the conduct of trade or business within the U.S. (unless claiming treaty benefits). . . . . W-8ECI
- A foreign partnership, a foreign simple trust, or a foreign grantor trust (unless claiming treaty benefits) (see instructions for exceptions) . . . W-8IMY
- A foreign government, international organization, foreign central bank of issue, foreign tax-exempt organization, foreign private foundation, or government of a U.S. possession claiming that income is effectively connected U.S. income or that is claiming the applicability of section(s) 115(2), 501(c), 892, 895, or 1443(b) (unless claiming treaty benefits) (see instructions) . . . . . W-8ECI or W-8EXP
- Any person acting as an intermediary . . . . . W-8IMY

## Part I Identification of Beneficial Owner

1 Name of organization that is the beneficial owner	2 Country of incorporation or organization
---	--

3 Name of disregarded entity receiving the payment (if applicable)

4 Chapter 3 Status (entity type) (Must check one box only):

<input type="checkbox"/> Corporation	<input type="checkbox"/> Disregarded entity	<input type="checkbox"/> Partnership
<input type="checkbox"/> Simple trust	<input type="checkbox"/> Grantor trust	<input type="checkbox"/> Complex trust
<input type="checkbox"/> Central Bank of Issue	<input type="checkbox"/> Tax-exempt organization	<input type="checkbox"/> Estate
<input type="checkbox"/> Private foundation		<input type="checkbox"/> Government

If you entered disregarded entity, partnership, simple trust, or grantor trust above, is the entity a hybrid making a treaty claim? If "Yes" complete Part III.  Yes  No

5 Chapter 4 Status (FATCA status) (Must check one box only unless otherwise indicated). (See instructions for details and complete the certification below for the entity's applicable status).

<input type="checkbox"/> Nonparticipating FFI (including a limited FFI or an FFI related to a Reporting IGA FFI other than a registered deemed-compliant FFI or participating FFI). <input type="checkbox"/> Participating FFI. <input type="checkbox"/> Reporting Model 1 FFI. <input type="checkbox"/> Reporting Model 2 FFI. <input type="checkbox"/> Registered deemed-compliant FFI (other than a reporting Model 1 FFI or sponsored FFI that has not obtained a GIIN). <input type="checkbox"/> Sponsored FFI that has not obtained a GIIN. Complete Part IV. <input type="checkbox"/> Certified deemed-compliant nonregistering local bank. Complete Part V. <input type="checkbox"/> Certified deemed-compliant FFI with only low-value accounts. Complete Part VI. <input type="checkbox"/> Certified deemed-compliant sponsored, closely held investment vehicle. Complete Part VII. <input type="checkbox"/> Certified deemed-compliant limited life debt investment entity. Complete Part VIII. <input type="checkbox"/> Certified deemed-compliant investment advisors and investment managers. Complete Part IX. <input type="checkbox"/> Owner-documented FFI. Complete Part X. <input type="checkbox"/> Restricted distributor. Complete Part XI.	<input type="checkbox"/> Nonreporting IGA FFI (including an FFI treated as a registered deemed-compliant FFI under an applicable Model 2 IGA). Complete Part XII. <input type="checkbox"/> Foreign government, government of a U.S. possession, or foreign central bank of issue. Complete Part XIII. <input type="checkbox"/> International organization. Complete Part XIV. <input type="checkbox"/> Exempt retirement plans. Complete Part XV. <input type="checkbox"/> Entity wholly owned by exempt beneficial owners. Complete Part XVI. <input type="checkbox"/> Territory financial institution. Complete Part XVII. <input type="checkbox"/> Nonfinancial group entity. Complete Part XVIII. <input type="checkbox"/> Excepted nonfinancial start-up company. Complete Part XIX. <input type="checkbox"/> Excepted nonfinancial entity in liquidation or bankruptcy. Complete Part XX. <input type="checkbox"/> 501(c) organization. Complete Part XXI. <input type="checkbox"/> Nonprofit organization. Complete Part XXII. <input type="checkbox"/> Publicly traded NFFE or NFFE affiliate of a publicly traded corporation. Complete Part XXIII. <input type="checkbox"/> Excepted territory NFFE. Complete Part XXIV. <input type="checkbox"/> Active NFFE. Complete Part XXV. <input type="checkbox"/> Passive NFFE. Complete Part XXVI. <input type="checkbox"/> Excepted inter-affiliate FFI. Complete Part XXVII. <input type="checkbox"/> Direct reporting NFFE. <input type="checkbox"/> Sponsored direct reporting NFFE. Complete Part XXVIII.
---	---

6 Permanent residence address (street, apt. or suite no., or rural route). **Do not use a P.O. box or in-care-of address** (other than a registered address).

City or town, state or province. Include postal code where appropriate.	Country
---	---------

7 Mailing address (if different from above)

City or town, state or province. Include postal code where appropriate.	Country
---	---------

8 U.S. taxpayer identification number (TIN), if required	9a <input type="checkbox"/> GIIN	b <input type="checkbox"/> Foreign TIN	10 Reference number(s) (see instructions)
--	----------------------------------	--	---

**Note.** Please complete remainder of the form including signing the form in Part XXIX.



# Request for Taxpayer Identification Number and Certification

**Give Form to the  
 requester. Do not  
 send to the IRS.**

<b>Print or type See Specific Instructions on page 2.</b>	<b>1</b> Name (as shown on your income tax return). Name is required on this line; do not leave this line blank.	
	<b>2</b> Business name/disregarded entity name, if different from above	
	<b>3</b> Check appropriate box for federal tax classification; check only <b>one</b> of the following seven boxes: <input type="checkbox"/> Individual/sole proprietor or single-member LLC <input type="checkbox"/> Limited liability company. Enter the tax classification (C=C corporation, S=S corporation, P=partnership) ▶ _____ <b>Note.</b> For a single-member LLC that is disregarded, do not check LLC; check the appropriate box in the line above for the tax classification of the single-member owner. <input type="checkbox"/> Other (see instructions) ▶ _____	<b>4</b> Exemptions (codes apply only to certain entities, not individuals; see instructions on page 3): Exempt payee code (if any) _____ Exemption from FATCA reporting code (if any) _____ <i>(Applies to accounts maintained outside the U.S.)</i>
	<b>5</b> Address (number, street, and apt. or suite no.)	Requester's name and address (optional)
	<b>6</b> City, state, and ZIP code	
	<b>7</b> List account number(s) here (optional)	

## Part I Taxpayer Identification Number (TIN)

Enter your TIN in the appropriate box. The TIN provided must match the name given on line 1 to avoid backup withholding. For individuals, this is generally your social security number (SSN). However, for a resident alien, sole proprietor, or disregarded entity, see the Part I instructions on page 3. For other entities, it is your employer identification number (EIN). If you do not have a number, see *How to get a TIN* on page 3.

**Note.** If the account is in more than one name, see the instructions for line 1 and the chart on page 4 for guidelines on whose number to enter.

<b>Social security number</b>	
<b>or</b>	
<b>Employer identification number</b>	

## Part II Certification

Under penalties of perjury, I certify that:

1. The number shown on this form is my correct taxpayer identification number (or I am waiting for a number to be issued to me); and
2. I am not subject to backup withholding because: (a) I am exempt from backup withholding, or (b) I have not been notified by the Internal Revenue Service (IRS) that I am subject to backup withholding as a result of a failure to report all interest or dividends, or (c) the IRS has notified me that I am no longer subject to backup withholding; and
3. I am a U.S. citizen or other U.S. person (defined below); and
4. The FATCA code(s) entered on this form (if any) indicating that I am exempt from FATCA reporting is correct.

**Certification instructions.** You must cross out item 2 above if you have been notified by the IRS that you are currently subject to backup withholding because you have failed to report all interest and dividends on your tax return. For real estate transactions, item 2 does not apply. For mortgage interest paid, acquisition or abandonment of secured property, cancellation of debt, contributions to an individual retirement arrangement (IRA), and generally, payments other than interest and dividends, you are not required to sign the certification, but you must provide your correct TIN. See the instructions on page 3.

<b>Sign Here</b>	Signature of U.S. person ▶	Date ▶
------------------	----------------------------	--------

## General Instructions

Section references are to the Internal Revenue Code unless otherwise noted.

**Future developments.** Information about developments affecting Form W-9 (such as legislation enacted after we release it) is at [www.irs.gov/fw9](http://www.irs.gov/fw9).

### Purpose of Form

An individual or entity (Form W-9 requester) who is required to file an information return with the IRS must obtain your correct taxpayer identification number (TIN) which may be your social security number (SSN), individual taxpayer identification number (ITIN), adoption taxpayer identification number (ATIN), or employer identification number (EIN), to report on an information return the amount paid to you, or other amount reportable on an information return. Examples of information returns include, but are not limited to, the following:

- Form 1099-INT (interest earned or paid)
- Form 1099-DIV (dividends, including those from stocks or mutual funds)
- Form 1099-MISC (various types of income, prizes, awards, or gross proceeds)
- Form 1099-B (stock or mutual fund sales and certain other transactions by brokers)
- Form 1099-S (proceeds from real estate transactions)
- Form 1099-K (merchant card and third party network transactions)

- Form 1098 (home mortgage interest), 1098-E (student loan interest), 1098-T (tuition)
- Form 1099-C (canceled debt)
- Form 1099-A (acquisition or abandonment of secured property)

Use Form W-9 only if you are a U.S. person (including a resident alien), to provide your correct TIN.

*If you do not return Form W-9 to the requester with a TIN, you might be subject to backup withholding. See What is backup withholding? on page 2.*

By signing the filled-out form, you:

1. Certify that the TIN you are giving is correct (or you are waiting for a number to be issued),
2. Certify that you are not subject to backup withholding, or
3. Claim exemption from backup withholding if you are a U.S. exempt payee. If applicable, you are also certifying that as a U.S. person, your allocable share of any partnership income from a U.S. trade or business is not subject to the withholding tax on foreign partners' share of effectively connected income, and
4. Certify that FATCA code(s) entered on this form (if any) indicating that you are exempt from the FATCA reporting, is correct. See *What is FATCA reporting?* on page 2 for further information.